

This drawing may not be copied, reproduced or made available to third parties in any way whatsoever without or prior written approval.

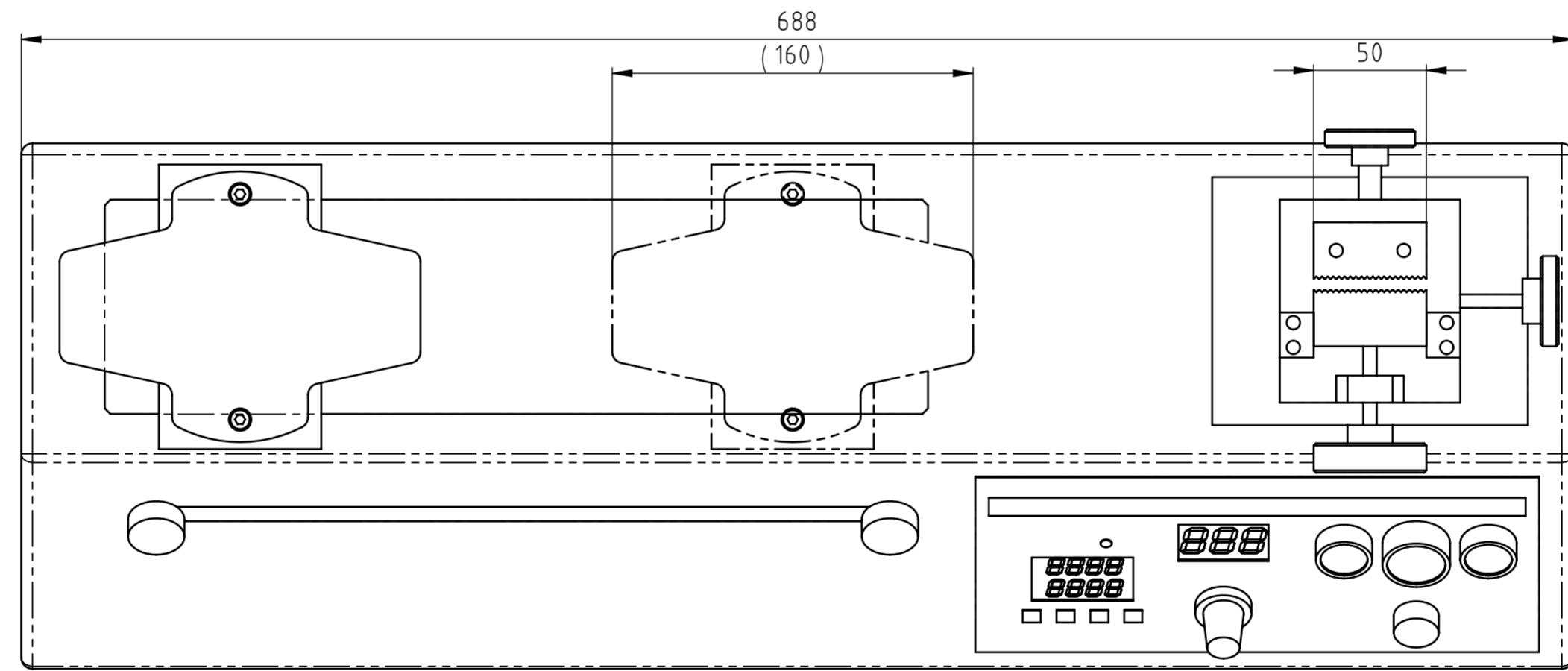

NUR ZUR INFORMATION!

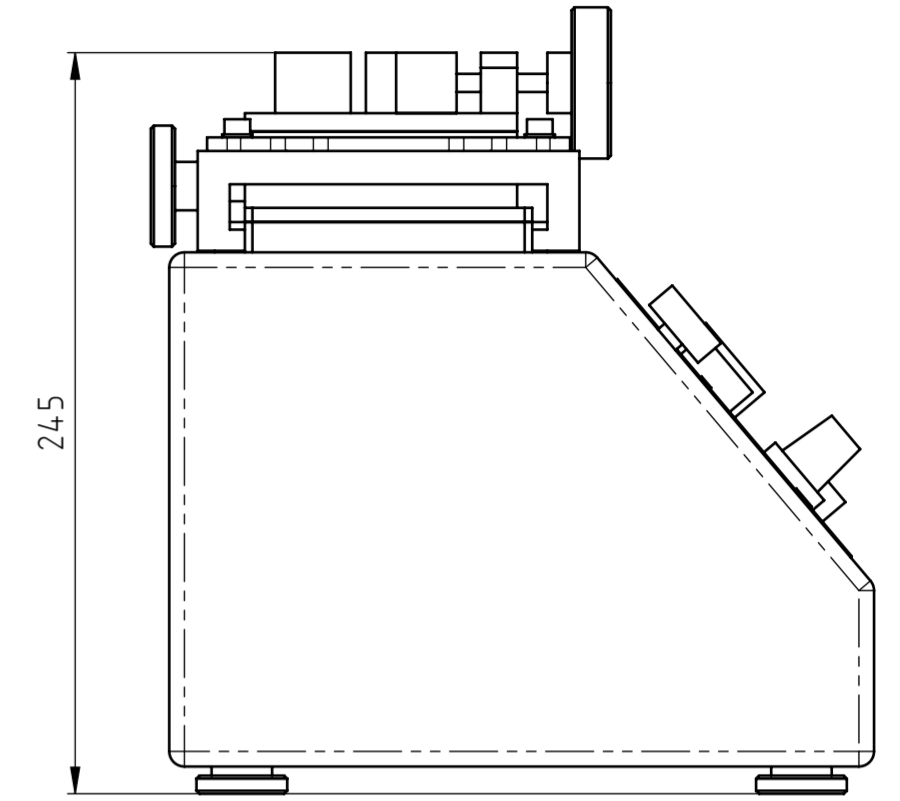
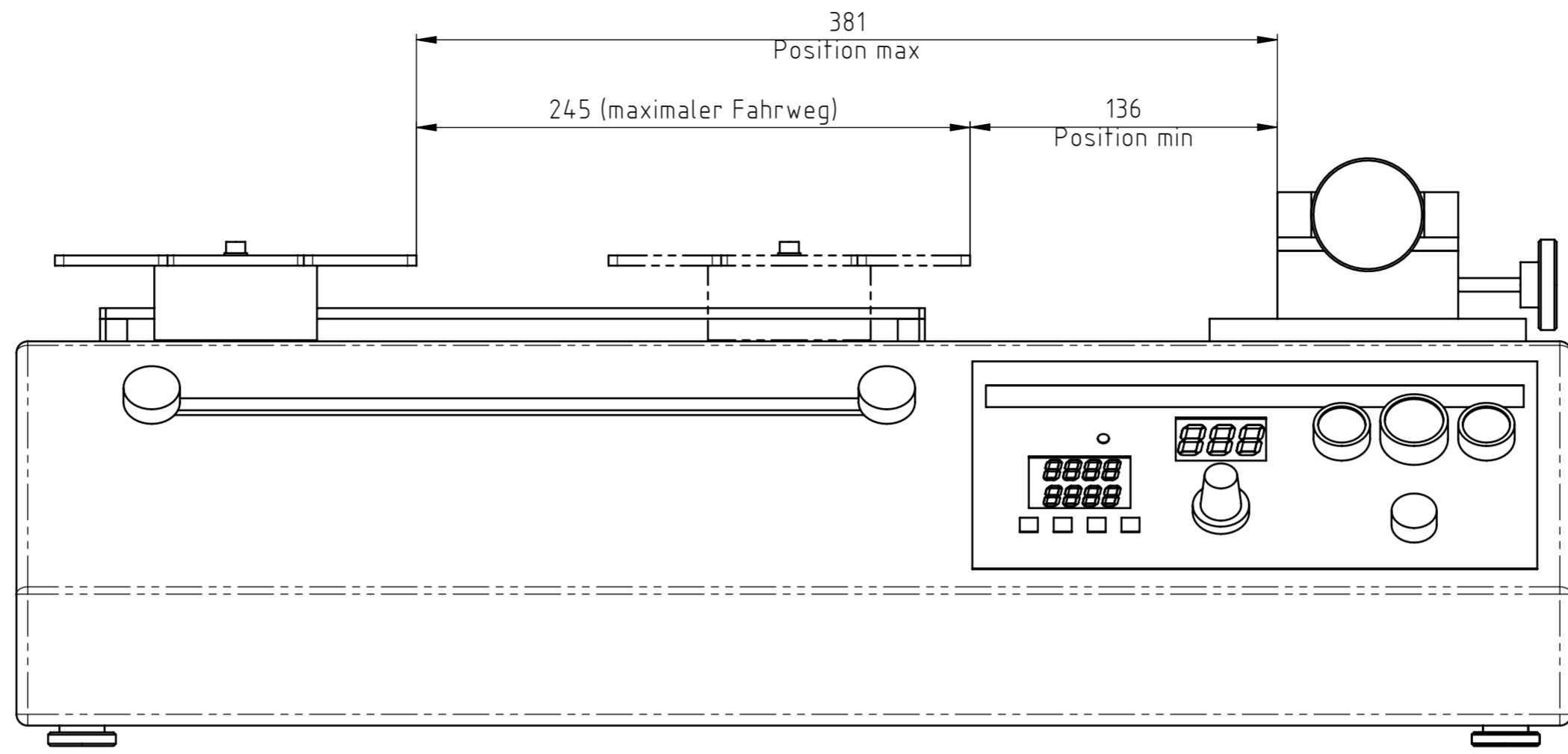
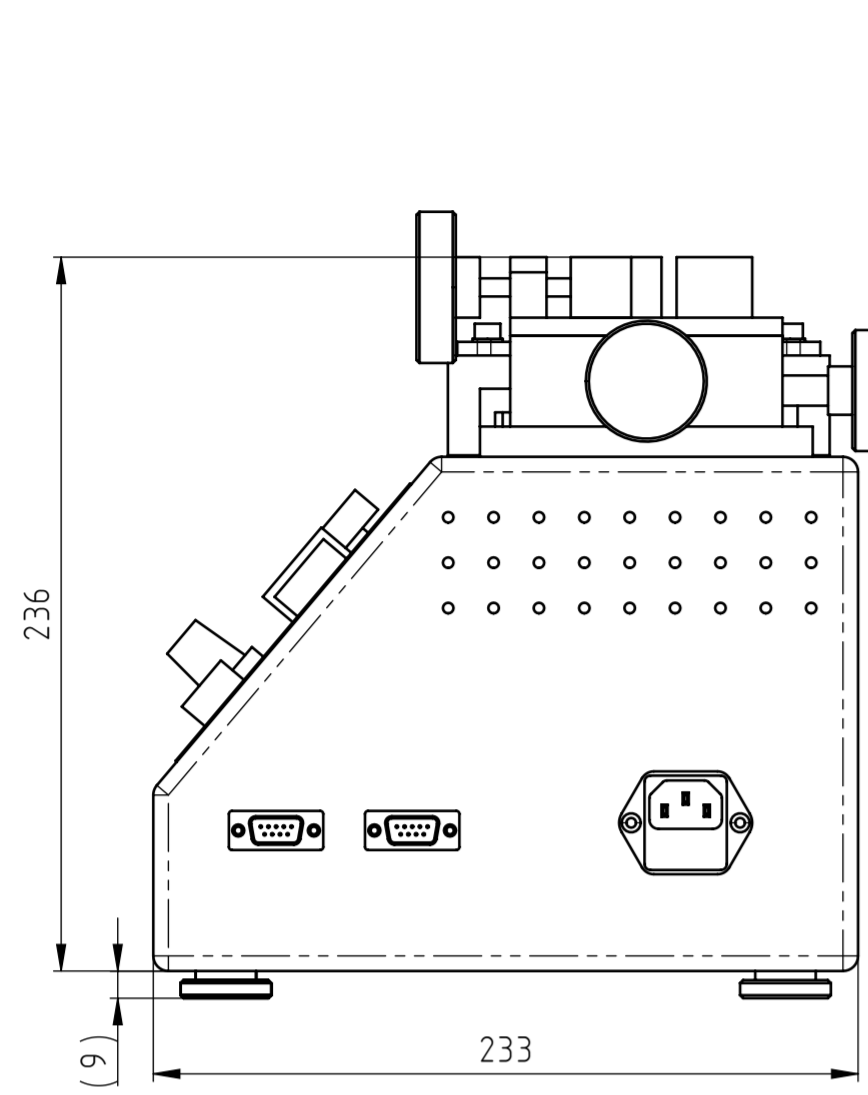
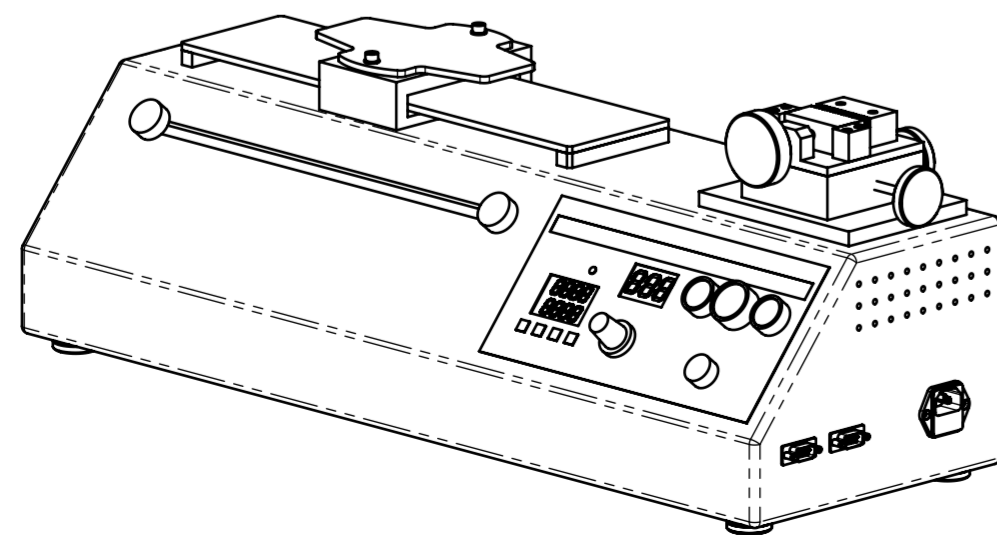

1:5

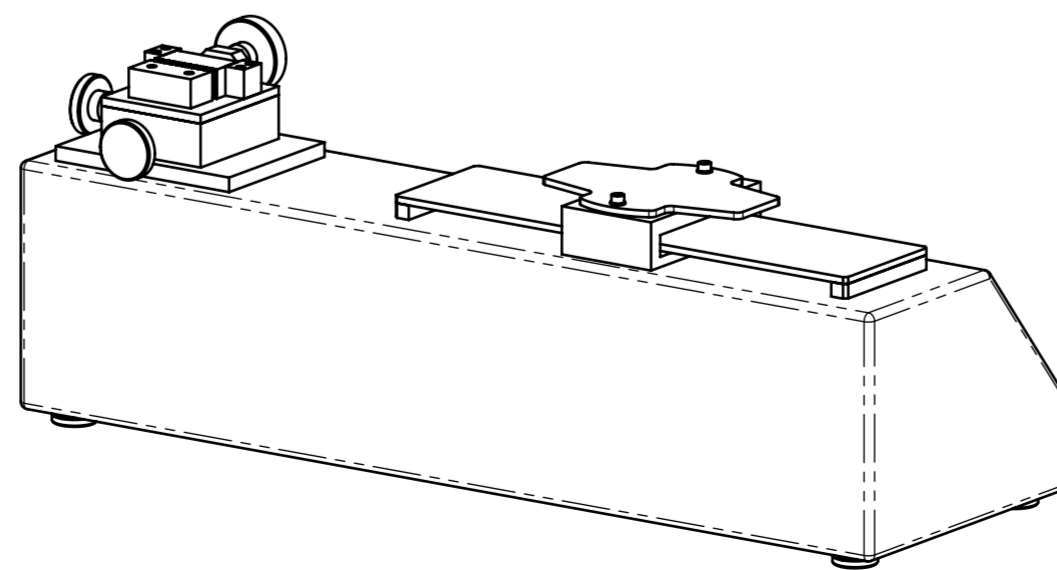

Der Lieferant erkennt mit der Annahme der Zeichnung an, dass er in der Lage ist, das dargestellte Teil nach Zeichnung reproduzierbar in der Serie herzustellen. Durch die gewählten Herstellungsverfahren entstehen keine Beeinträchtigungen an Material und Gefüge, die zur späteren Beeinträchtigung des Bauteils führen können. Mündliche Vereinbarungen darüber hinaus haben keine Gültigkeit. Abweichungen von dieser Regel bedürfen der Schriftform und müssen vom Auftraggeber gegengezeichnet werden.

The supplier acknowledges that, with the acceptance of the drawing, he is in a position to manufacture the illustrated part in accordance with the drawing in reproducible form and series production. Through the selected manufacturing processes no impairments will arise in the material and structure which could subsequently lead to an impairment of the component. Verbal agreements over and above that are not valid. Deviations from this rule must be written and must be signed by the purchaser.

tolerance ISO 2768-mk		part edges DIN6784		article number	material
> 0,5-6	±0,1	-0,2 +0,2	-	-	-
> 6-30	±0,2			format DIN	standard
> 30-120	±0,3	A2	1:2.5	-	-
> 120-315	±0,4			tolerance ISO 8015	assembly THM
> 315-1000	±0,5			roughness serie3 ISO 1302	
				2007 date	name
				edited 21.11.17	kp/condi
				proven	
				Teststand THM 500N500S	
				- schematisch -	
				drawing number	index
				-	0.0
				Mdl: Prüfstand_THM_500N500S_Frontalansicht_THM_500N500S_komplett	
				replace for	replace by
index	change	date	name	sheet 1 of 1	

